
Best Practice Guide 5

Electrical installations and their impact on the fire performance of buildings:

**Part 1 - Domestic premises:
Single family units
(houses, flats, maisonettes,
bungalows)**

BestPracticeGuide

Electrical Safety First is indebted to the following organisations for their contribution and/or support to the development of this Guide:

	Association of Building Engineers www.abe.org.uk
	BEAMA www.beama.org.uk
	British Gypsum www.british-gypsum.com
	BSI Product Services www.bsigroup.com
	CEDIA UK www.cedia.co.uk
	Chief Fire Officers' Association www.cfoa.org.uk
	Electrical Contractors' Association www.eca.co.uk
	ELECSA www.elecsa.org.uk
	Institution of Engineering and Technology www.theiet.org
	Intumescent Fire Seals Association www.ifsa.org.uk
	Knauf Drywall www.knaufdrywall.co.uk
	LABC www.labc.co.uk
	Lighting Association www.lightingassociation.com
	Lighting Industry Federation www.lif.co.uk
	NAPIT www.napit.org.uk
	NHBC www.nhbc.co.uk
	NICEIC www.niceic.com
	SELECT (Electrical Contractors' Association of Scotland) www.select.org.uk
	Tenmat Ltd www.tenmat.com

This is one of a series of **Best Practice Guides** produced by Electrical Safety First* in association with leading industry bodies for the benefit of electrical contractors and installers, and their customers.

Consultants to Electrical Safety First:



International Fire Consultants Ltd
www.intfire.com

In electronic format, this Guide is intended to be made available free of charge to all interested parties. Further copies may be downloaded from the websites of some of the contributing organisations.

The version of this Guide on the Electrical Safety First website (www.electricalsafetyfirst.org.uk) will always be the latest. Feedback on any of the Best Practice Guides is always welcome – email bpg@electricalsafetyfirst.org.uk

Electrical Safety First is supported by all sectors of the electrical industry, approvals and research bodies, consumer interest organisations, the electrical distribution industry, professional institutes and institutions, regulatory bodies, trade and industry associations and federations, trade unions, and local and central government.

*Electrical Safety First (formerly the National Inspection Council for Electrical Installation Contracting) is a charitable non-profit making organisation set up in 1956 to protect users of electricity against the hazards of unsafe and unsound electrical installations.

Published by:

Electrical Safety First
The UK's electrical safety experts

Electrical Safety First
Unit 331
Metal Box Factory
30 Great Guildford Street
London SE1 0HS

Tel: 0203 463 5100

Email: bpg@electricalsafetyfirst.org.uk

Website: www.electricalsafetyfirst.org.uk

Electrical Safety First and other contributors believe that the guidance and information contained in this Best Practice Guide is correct, but all parties must rely on their own skill and judgement when making use of it. Neither Electrical Safety First nor any contributor assumes any liability to anyone for any loss or damage caused by any error or omission in this Guide, whether such error or omission is the result of negligence or any other cause. Where reference is made to legislation, it is not to be considered as legal advice. Any and all such liability is disclaimed.

© Electrical Safety Council. March 2014

Electrical Installations and their impact on the fire performance of buildings:

Part 1 - Domestic premises: Single family units (houses, flats, maisonettes, bungalows)



Photo courtesy of Greater Manchester Fire & Rescue Service

1 Aim

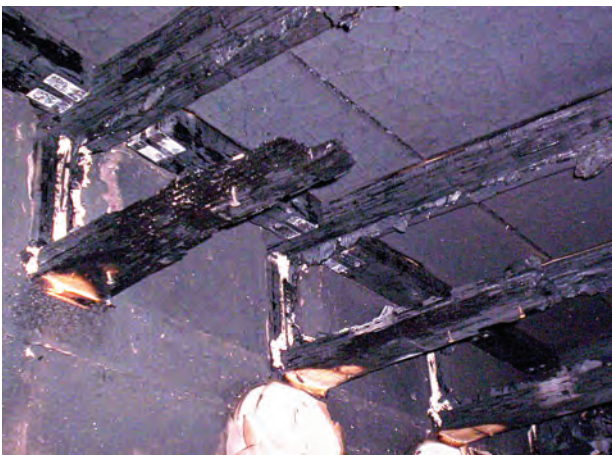
- 1.1 The aim of this Guide is to promote best practice by providing practical advice and guidance for designers, installers, verifiers and inspectors of domestic electrical installations where, as is often the case, the electrical work requires, or has required, the penetration of linings forming ceilings and walls.
- 1.2 The guidance, which is intended to apply to electrical installations designed after July 2008, may also be of benefit to specifiers, builders, building control bodies and other interested parties.
- 1.3 By following the guidance, it is considered that electrical installation work will not compromise the fire performance provisions that are mandatorily required to be incorporated into domestic premises under the relevant building regulations.

2 Introduction

- 2.1 This Guide has been produced by Electrical Safety First in association with the bodies indicated on page 2.
- 2.2 It addresses the impact that electrical installations in domestic premises have on the fire performance of loadbearing and non-loadbearing walls and floors (and sometimes ceiling membranes) that have a fire containment function, or are required to carry a load for a prescribed period.
- 2.3 Fire safety in buildings generally requires that in the event of a fire:
 - certain walls, floors and ceilings provide fire separation for the purposes of constructing fire compartments and/or protected escape routes, and
 - the structure resists collapse.

2.4 The advice given in this Guide is aimed largely at preserving the structural stability of the premises as much as the fire separation between areas. **For example, in most domestic premises, it is the loadbearing capacity of the floors that is threatened by early failure of ceiling linings, not the fire separating function.**

2.5 Many modern forms of engineered construction have an inherently lower level of fire resistance when compared to more traditional forms of construction, and are heavily reliant on the plasterboard or similar linings for achieving the requisite level of fire separation.



*Result of an eight minute fire on lightweight joists
(Courtesy of Manchester City Council - Building Control)*

2.6 Much of the guidance is related to the effect that the installation of electrical equipment will have on the performance of the protective linings that are used to provide fire protection to lightweight joisted or studded constructions. In the case of the associated wiring, the need to prevent fire from passing through holes in all elements, whether solid or lightweight, is also addressed.

2.7 Amongst these forms of construction are narrow section solid, stress graded timber joists, plywood/Orientated Strand Board (OSB) webbed I joists ('timber I beams'), tooth or nail-plated trusses and joists, composite timber studs and lightweight metal studs. Illustrations of these vulnerable forms of construction are to be found in Annex A.

2.8 The fire resistance of these elements can easily be compromised by inadequate fire sealing and 'making good' after any penetration to accommodate electrical equipment and associated wiring.

2.9 Electrical equipment that has been identified as having a direct and significant influence on the fire performance of buildings includes:

- flush-mounted consumer units
- concealed and recessed luminaires, including downlighters
- flush-mounted electrical socket-outlets, flex outlet plates and data points
- flush-mounted switches, detection and control devices
- recessed wall luminaires
- concealed speakers.

2.10 The above items all require the removal of a part of the ceiling or wall lining, and replacement with glass, thin metal or plastic that does not provide the same level of fire protection to the structural members, causing a reduction in the fire performance of the element. **These are known as partial penetrations.**

2.11 In addition to the influence that these partial penetrations have on the fire performance, some installations can penetrate both linings, such as:

- associated wiring and conduits
- ventilation fans and related ductwork.

2.12 These installations have a potential to compromise the fire containment capability, and guidance is included for these situations. **These are known as full penetrations.**

2.13 In addition to the above items that all have a direct influence on the fire performance of floors or walls, the following items can also have an indirect influence if the lining provides some or all of their support:

- heavy ceiling-hung luminaires, lighting tracks and overhead projectors
- wall-mounted brackets for televisions, heavy speakers and flat screen installations.

If the room is involved in fire, the weight of such items may lead to the premature failure of the lining material.

- 2.14 In addition to the risk of the electrical installation reducing the fire separation capabilities of those elements that need to resist fire spread or to remain structurally sound in a fire, a poorly constructed installation can potentially be the cause of a fire, for example due to heat generated by loose connections.
- 2.15 This Guide addresses all of these issues.
- 2.16 The fire separating capability of an element of construction is generally measured by the duration for which the element will satisfy the criteria of a fire resistance test. Historically, these criteria have been determined by exposure to the BS 476: Part 20: 1987 heating and pressure conditions, but more recently by the new European testing regime as embodied in BS EN 1363-1. More information on the relevant test methods and criteria can be found in Annex B.



3 Scope

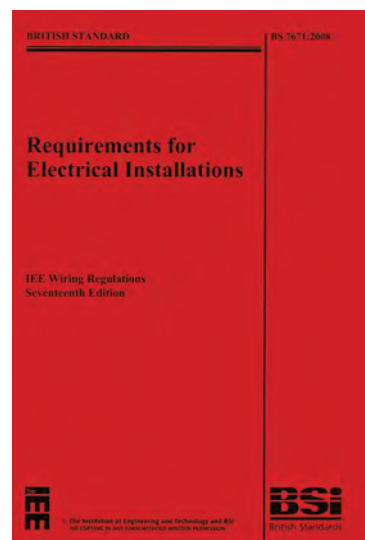
- 3.1 This Guide gives practical advice and guidance for the installation, and the making good following the installation, of electrical equipment and wiring in self-contained domestic premises (including bungalows, multi-storey houses, individual flats and maisonettes) that are designed to accommodate a single family unit. The advice and guidance applies to both new and existing premises.
- 3.2 The Guide does not apply directly to Houses in Multiple Occupation, hostels, caravans or boats, or to the communal parts of blocks of flats or the communal parts of maisonettes, nor does it apply to any premises used for purposes other than a dwelling (such as small shops, factories or similar premises used solely as places of work). Guidance for these building types may be found in other Parts of this Best Practice Guide (in preparation).
- 3.3 The Guide gives advice on what needs to be done to maintain the fire resistance of walls and ceilings in domestic premises that have been penetrated or partially penetrated in the process of installing electrical equipment and wiring.
- 3.4 It does not consider in detail the impact that the installation of electrical equipment and wiring may also have on the structural, acoustic or energy targets prescribed in building regulations.
- 3.5 The Guide gives recommendations as to what is considered to be best practice, taking into account that electrical installers may not have adequate knowledge of the construction of the elements that are potentially being compromised by their work.
- 3.6 Where an installer wishes to differentiate between new and traditional forms of construction, the guidance given in Annex C may assist. Some investigations may require the services of another professional, such as a surveyor or fire specialist.

Note: This Guide does not necessarily apply to all innovative or unusual forms of construction or electrical equipment. If in doubt, specialist advice should be sought.

4 General electrical installation requirements

- 4.1 This Guide takes into account the publication of BS 7671: 2008 (*Requirements for Electrical Installations, IEE Wiring Regulations 17th Edition*), which is the latest version of the national standard for the safety of electrical installations, first published in 1882.
- 4.2 BS 7671 requires, in Section 421 (*Protection against fire caused by electrical equipment*), that equipment must not present a fire hazard to adjacent materials, and that manufacturers' instructions must be complied with. Section 421 also requires that fixed equipment causing a concentration and focusing of heat (such as spotlamps) shall be at a sufficient distance from any fixed object or building element so that the object or element is not subjected to a dangerous temperature in normal conditions.
- 4.3 Also, in Section 527 (*Selection and erection of wiring systems to minimise the spread of fire*) of that standard, it is required that wiring systems are selected and erected to minimise the spread of fire, including:
- Within a fire-segregated compartment, the risk of the spread of fire must be minimised by the selection of appropriate materials, and by the appropriate construction of the installation (Regulation 527.1.1), and
 - A wiring system must be installed so that the general building structural performance and fire safety performance are not reduced (Regulation 527.1.2), and
 - Where a wiring system passes through elements of building construction such as floors, walls, roofs, ceilings, partitions or cavity barriers, the openings remaining after the passage of the wiring system must be sealed according to the degree of fire resistance (if any) prescribed for the respective element of building construction before penetration (Regulation 527.2.1).

- 4.4 Regulation 510.2 requires manufacturers' instructions to be taken into account. It is important to do this in order, for example, to prevent luminaires becoming a source of ignition. (Any installation instructions that are considered to be inappropriate should be queried with the manufacturer concerned, and amended installation instructions requested.)
- 4.5 All terminations and joints, whether for low voltage (LV) or extra-low voltage (ELV) circuits, should be enclosed in accordance with Regulation 526.5 to prevent fire spread should a loose connection occur.
- 4.6. As part of the initial verification process, the electrical installer has a duty to ensure that all the necessary fire precautions have been taken, irrespective of which party was responsible for that element of the electrical work (Regulation 611.3(vii)).



5 Legal

- 5.1 Building regulations for each part of the UK define fire performance objectives for the various elements that make up domestic premises, and give recommended performance levels in guidance supporting those regulations. The objectives are taken into account in this Guide. For further information, see Annex D.
- 5.2 It is vital that the fire performance of critical walls and floors is maintained to at least the level recommended in the guidance supporting the regulations, after the installation of electrical equipment and associated wiring.
- 5.3 For properties in England and Wales, attention is drawn to the Party Wall Act. Under this Act, any work undertaken on the party wall between properties which could affect its performance (or indirectly affect the structure of an attached neighbouring property) is a notifiable activity. In Scotland, a building warrant is required for any work that adversely affects a separating wall or a separating floor.
- 5.4 The fitting of electrical equipment in a masonry party wall has never been considered as being notifiable, but cutting holes in the linings and installing 'plastic' accessories may be deemed to be covered by statutory requirements. Electrical Safety First therefore recommends that the neighbour be advised of the intended work in order to give them the opportunity to object to, comment upon, or prevent the work taking place.
- 5.5 Electrical installation work will often be undertaken on behalf of owners or tenants after the occupation of the premises and, as such, it is not subject to any form of third party audit or final approval. The electrical installer is therefore subject to a duty of care to ensure that the fire performance of the premises is not compromised. In Scotland, certain works require building warrant approval depending on the work proposed and the building type.

Note: In England & Wales, Part P of the Building Regulations and, in Scotland, Building Standard 4.5, make this a requirement, putting the responsibility on the installer if self-certifying the work as compliant with building regulations. Currently, electrical safety in Northern Ireland is not controlled under building regulations.

RECOMMENDATIONS

6 Flush-mounted consumer units



Photos courtesy of Hager

- 6.1 Flush-mounted consumer units should not be installed in a fire separating wall. In exceptional circumstances, where this cannot be avoided, and subject to the agreement of the Local Authority, the enclosure of the consumer unit or a separate builder's work enclosure around the consumer unit must provide a proven level of fire resistance commensurate with the fire separating element.



Photo courtesy of MK

7 Downlighters (recessed luminaires)

- 7.1 When exposed to a fire from below, downlighters may provide far less protection to a cavity and the structural elements within it than the plasterboard they are replacing, unless suitable precautions are taken.
- 7.2 Electrical Safety First recommends that, wherever possible, downlighters having integral fire protection are selected for use in **all** ceilings where the lining that is to be penetrated is the sole means of keeping fire and heat out of the cavity.



Result of a downlighter fire
(Courtesy of Manchester City Council - Building Control)

- 7.3 There are a number of types of downlighter available, and it is important that the type selected for a particular application has test evidence to support its fire performance **when incorporated in a ceiling of the type into which it is to be installed.**



Typical downlighters with integral fire protection
(Photos courtesy of Safe and Sound Lighting Ltd)

- 7.4 Generally, the tests should have been carried out in accordance with BS 476: Part 21: 1987 or BS EN 1365-2. The nature of the test evidence can be critical, and is discussed in detail in Annex B.

- 7.5 Not all designs and styles of downlighter may be available with integral fire protection, especially where higher lighting levels and/or larger coverage is required. In these situations, additional fire protection may be fitted at the time of installation in the form of a 'fire hood', an insulated fire-protective box, or similar.



Typical fire hood for a downlighter

- 7.6 Such separate forms of protection must be fit for purpose and not be easily dislodged or compromised after installation by subsequent work. Any such protection must conform to the guidance given in Annex E.
- 7.7 Electrical Safety First recommends that downlighters installed in a ceiling beneath a roof space have integral fire protection, or are provided with some other suitable form of fire protection, in order to safeguard escape from the premises, restrict the spread of fire, and reduce the risk of premature failure of the roof structure.
- 7.8. In order to avoid the risk of fire (as well as reduced lamp and service life) caused by overheating, downlighters and any associated transformers must not be covered by thermal insulation. Building Regulations do not prohibit the leaving of a small area around downlighters free from thermal insulation where this is necessary to permit the dissipation of the heat they generate. However, due allowance for this should be made in the overall thermal performance of the premises.
- 7.9 In all cases, manufacturers' installation instructions must be followed to avoid downlighters becoming a source of fire.
- 7.10 Guidance on the selection of suitable types of downlighter for particular applications is given in Table 1, opposite.

Table 1: Recommendations for recessed luminaires/downlighters in floors and ceilings

Building	Location	Construction	Fire Resistance Required	Recommended
Bungalow	Roof ceiling	All	N/A	A*
Two-storey house	Roof ceiling	All	N/A	A* (assuming adequate compartmentation between adjacent dwellings)
	First Floor	Robust	Modified 30 mins**	B, C, but A can be justified if traditional construction confirmed (Annex C)
	Below room over garage	Lightweight ■	Modified 30 mins**	B, C
	Over basement	All	30 mins	B*, C*
Three-storey house	Over basement	All	30 mins	B, C
	Roof ceiling	All	N/A	A* (assuming adequate compartmentation between adjacent dwellings)
	First and Second Floor	All	30mins	B, C
	Ceiling of garage under room	All	30 mins	B*, C*
Loft conversion (2-storeys to 3)	Over basement	All	30 mins	B, C
	First floor (when loft converted)	Robust	Modified 30 mins**	B, C, but A can be justified if traditional construction confirmed (Annex C)
Four-storey (or more) house	Lightweight ■	All	Modified 30 mins**	B, C
	Roof ceiling	All	N/A	A* (Assuming adequate compartmentation between adjacent dwellings)
Flats	All Floors, including garage and basement ceilings/ floors	All	60 mins	B, C
	Compartment floor	All	30 min	D, B*, C*, ○
	Compartment floor	All	60 min	D, B*, C*, ○
	Compartment floor	All	90 min	D, B*, C*, ○
Duplex flats	Compartment floor	All	120 min	D, B*, C*, ○
	Intermediate floor	All	30 min	B, C

KEY:

- A = Unprotected downlighter permitted, but suitable fire protection recommended for safety reasons
- B = Downlighter with integral protection
- C = Downlighter with hood complying with Annex E
- D = Downlighter inserted in false (secondary) ceiling
- * = Ensure that thermal insulation will not prejudice luminaire
- = Should only be installed if it can be verified that the penetration will not have an adverse impact on acoustic performance
- = Robust construction is defined in Annex C
- = Lightweight engineered construction is defined in Annex A
- ** = See Annex F

NOTE: In Scotland, the guidance clause 5.1.10 (Domestic Handbook) recommends that downlighters installed in the ceiling of a combustible separating floor are fitted within the depth of a secondary ceiling.

8 Flush-mounted accessories (including switches, sockets, flex outlet plates, data and telephone points etc)

8.1 Numerous flush-mounted accessories are common in modern homes. These generally comprise two components:

- a recessed housing, or back box
- a face plate with integral socket, switch mechanism, flex outlet etc, and associated wiring terminals.

8.2 Back boxes may be either moulded plastic or steel construction, but all designs incorporate large knock-out sections, many times greater in diameter than the cables passing through them, which make them very permeable in a fire after the face plate has been destroyed by the heat. This permeability will allow hot gases into the cavity of the wall much more rapidly than the plasterboard. For fire separating applications, and for applications relied upon to resist collapse, this should be guarded against by providing additional localised fire protection.



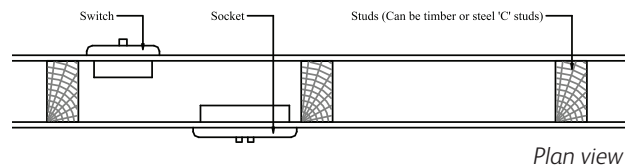
*The effect of fire on a socket-outlet
(Photo courtesy of Greater Manchester Fire & Rescue Service)*

8.3 The risks associated with fire penetrating through flush-mounted accessories are significant when they penetrate a 30 minute fire-resisting loadbearing stud wall, 'back-to-back' with other accessories in the same cavity (or interlinked cavities).

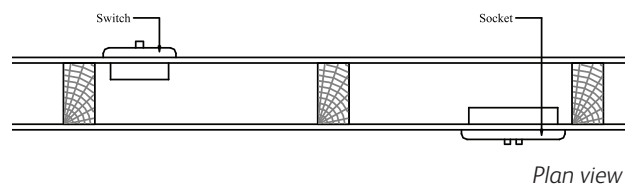


Photo courtesy of Greater Manchester Fire & Rescue Service

8.4 Therefore, where flush-mounted accessories penetrate each face of a 30 minute fire separating or loadbearing plasterboard lined wall within the same cavity space (that is, the gap between two studs), each accessory should be fitted with a back box that incorporates integral fire protection, or be fitted with a proprietary fire protection pad, unless evidence of the fire resistance performance of the accessories is available.

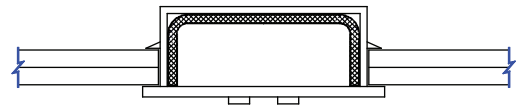


Example of accessories being back-to-back in the same cavity space (can be at different heights)



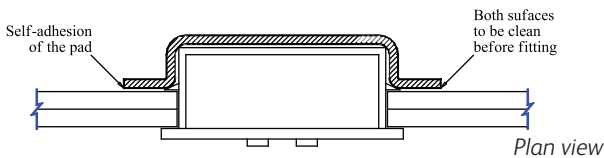
Example of accessories not being back-to-back in the same cavity

8.5 Such back boxes or protective pads must have evidence of performance to demonstrate that they have the ability to maintain the fire separation capability of a wall for 30 minutes, were they to be tested to BS 476: Part 21: 1987 (loadbearing) or BS 476: Part 22 (non-loadbearing), or the EN equivalent as appropriate (see Annex B), with plastic accessories fitted in both linings.

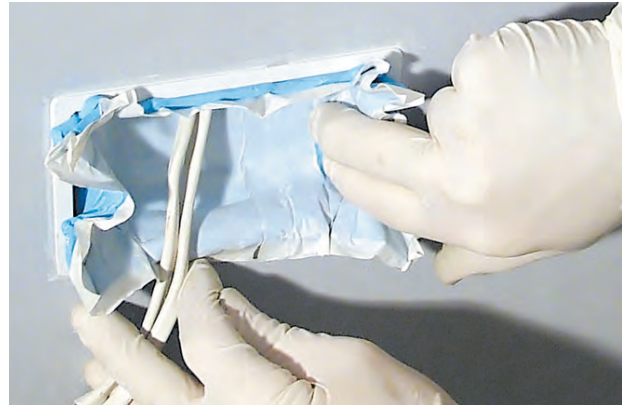


Plan view

The box depth must be selected so that with the pad in place, the required clearance is maintained between the pad and the accessory, and the wiring is not unduly distorted.



Fire protection pad fitted externally



Intumescent pad being installed in a dry lining box
(Photo courtesy of Knauf Drywall)



Fire and acoustic rated cover fitted behind a dry lining box
(Photo courtesy of Tenmat Ltd)



Intumescent insert being installed in a dry lining box
(Photo courtesy of Tenmat Ltd)

8.6 Recommendations for the protection of flush-mounted accessories in timber or metal stud walls in particular situations are given in Table 2 (on the following page).

Table 2: Recommendations for flush-mounted accessories in timber and metal stud walls

Building	Location	Installation	Fire Resistance Required	Recommended
All Dwelling Types	Internal walls within a dwelling that do not have a fire separating function	One lining only or back-to-back	N/A	A
Bungalow	Internal walls	One lining only or back-to-back	N/A	A
Two-storey house (detached)	Stairway enclosure	One lining only or back-to-back	N/A	A
	Wall separating garage from other rooms	One lining only Back-to-back	30 min 30 min	A B
Two-storey house (attached)	Stairway enclosure	One lining only or back-to-back	N/A	A
	Wall separating garage from other rooms	One lining only Back-to-back	30 min 30 min	A B
Three-storey house	Separating wall between dwellings #	Fitting in one or both linings #	60 min	B
	Stairway enclosure	One lining only Back-to-back	30 min 30 min	A B
Three-storey house (attached)	Wall separating garage from other rooms	One lining only Back-to-back	30 min 30 min	A B
	Stairway enclosure	One lining only Back-to-back	30 min 30 min	A B
Four-storey (or more) house	Wall separating garage from other rooms	One lining only Back-to-back	30 min 30 min	A B
	Stairway enclosure	One lining only Back-to-back	30 min 30 min	A B
Four-storey plus house (attached)	Wall separating garage from other rooms	One lining only Back-to-back	30 min 30 min	A B
	Stairway enclosure	One lining only Back-to-back	30 min 30 min	A B
Flats	Walls between occupancies #	Fitting in one or both linings	30 min	B [⊙]
	Walls between occupancies #	Fitting in one or both linings	60 min	B [⊙]
Duplex flats	Internal stairway enclosure	One lining only Back-to-back	30 min 30 min	A B

KEY:

A = Unprotected accessory

B = Accessory installed with applied or integral protection

* = Ensure that protection system will not prejudice wiring to accessory
 ⊙ = Should only be installed if it can be verified that the penetration will not have an adverse impact on acoustic performance
 # = Flush-mounted accessories should not be fitted in these walls unless unavoidable (Not permitted in Scotland)

NOTE: In Scotland, the guidance clause 2.2.7 (Domestic Handbook) recommends that combustible separating walls do not contain pipes, wires or other services. In buildings with a storey height over 18 m, separating walls and floors must be constructed of non-combustible materials.

9 Flush-mounted wall luminaires and concealed speakers in walls or ceilings

- 9.1 This type of equipment varies significantly in size, design and construction. It is therefore not possible to give specific advice in this Guide in respect of the best method of maintaining the fire performance of the lining(s) penetrated by such equipment.
- 9.2 In principle, however, speakers concealed in ceiling linings should be treated by analogy with downlighters, and both luminaires and speakers flush-mounted in walls should conform to the guidance given for flush-mounted accessories.
- 9.3 Where a luminaire or speaker has integral fire protection, then this must be to the appropriate test standard (see Annex B).



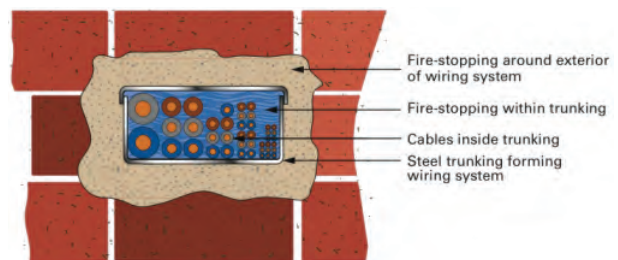
Photo courtesy of CEDIA/Smartcomm

- 9.4 If the equipment does not have integral fire protection then, when it is being installed in a ceiling or wall that is required to provide fire separation, the equipment has to be provided with an ad hoc form of fire protection and, where appropriate, acoustic insulation. It may be difficult for the installer to establish what form of protection is likely to maintain the required fire resistance, and therefore any proposed method of providing protection should be tested, or more reasonably assessed in lieu of test evidence, by those authorities recognised in guidance in support of regulations*.
- 9.5 Proprietary protection is likely to become available in due course, and should be used when it does.

* Approved Document B for the Building Regulations for England & Wales (A1 of Annex A), or the Scottish Building Standards Technical Handbook, as appropriate

10 Cables, conduit and trunking penetrating internal fire separating walls and floors

- 10.1 This section provides guidance as to what should be done to preserve the fire resistance of elements that are required to provide fire resistance, when cables have to pass through them. The guidance is applicable to situations where insulated and sheathed cables, or cables in plastic conduit or plastic trunking, pass through floors and walls.
- 10.2 The fire risk associated with non-fire performance cables and plastic conduits and trunking passing through building elements is twofold. Initially there is a risk of a loss of integrity due to the heat and/or flames passing through any unsealed holes that have been made to allow the cable to pass through, resulting in flaming on the unexposed side. Secondly, the hole in a plasterboard lining will allow fire to get into the ceiling or wall void prematurely, cause ignition of the structure which can lead to a loss of loadbearing capacity.
- 10.3 With respect to the first of these, it is important that fire is not allowed to exploit either the initial penetration of the first lining (which could permit fire to get into the cavity), or subsequently to penetrate the second lining (which would allow the fire to effectively bypass the protective barrier).



Fire seals around cables and trunking

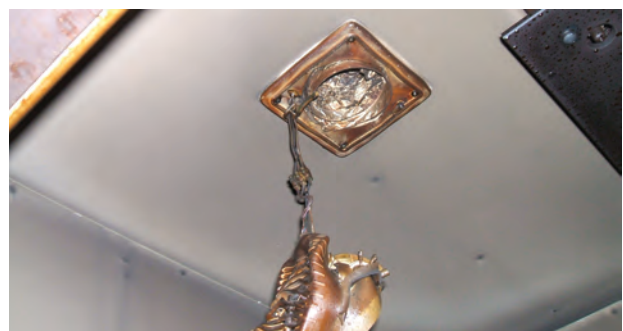
- 10.4 Sealing the cable ingress point has to take into account that the insulation of non-fire performance cables will probably melt or char away, leaving an unfilled gap between the conductors and the lining. Depending upon the nature of the cable insulation, this may even have the potential to carry the flames on its surface into the void. On a single cable this is unlikely to be a serious risk, but the ability to make an adequate fire seal becomes increasingly difficult as the number of cables increase.

- 10.5 It is common and accepted practice to make good any hole around a cable by using inert filler such as plaster or grout, but this does not compensate for melting/flaming insulation, and will also be ineffective in voids between cables.
- 10.6 It is recommended, therefore, that the sealant used to make good holes through which cables pass has intumescent properties: that is, it has the ability to expand and fill any voids that are developing due to movement and/or melting of cables, in order to maintain the fire resistance of the element.
- 10.7 The risk of fire gaining premature access to any void is increased if the cables are run through a plastic conduit or trunking system, or are bunched. Any cosmetic sealing of the gap between the lining and the plastic conduit or trunking will certainly not be able to seal any voids between the cables and the outer plastic casing following the melting of the conduit or trunking.
- 10.8 In elements that require high levels of fire resistance, especially where there is a sleeping risk (such as 60 minute compartment walls and floors), it is recommended that a proprietary cable transit or a fire resisting conduit be installed in the construction element being penetrated, if services have to pass through one or both linings that form the wall.

NOTE: In Scotland, the guidance clause 2.2.7 (Domestic Handbook) recommends that combustible separating walls do not contain pipes, wires or other services. In buildings with a storey height over 18 m, separating walls and floors must be constructed of non-combustible materials.

11 Ventilation fans and related ductwork

- 11.1 Ventilation fans are normally fitted on an external wall rather than on an internal wall and, as a consequence, there is generally not a fire safety issue regarding the influence on the integrity and insulation rating of the wall due to such systems when installed in a cavity blockwork or masonry wall.
- 11.2 However, if fire were to enter the cavity of a stud wall or the cavity between the inner wall and any outer 'sheathing', the building can suffer both undue structural damage if modern engineered construction is used, and/or disproportionate fire spread in the cavity in more conventional properties. This cavity spread can result in an indirect loss of fire integrity between adjacent internal enclosures, and therefore fire should be prevented from gaining access to any of the cavities.
- 11.3 When installing a ventilation fan directly into a loadbearing external stud construction wall, the hole cut into the inner and outer lining should be lined out across the thickness of the wall with a continuous non-combustible material, preferably with some insulating properties, through which the extract duct passes**. This liner should be fixed in place so that it does not fall away over time.
- 11.4 When the vent from for example, a shower cubicle, is connected to an extended duct which runs within the floor void to an outside wall possibly via an in-line fan, then this length of low melting point ductwork (plastic or aluminium) will have no measurable fire resistance and fire entering into this duct, via the vent, will soon have access to the joists. Indeed, should the fan be in extract mode at the time of the fire, fire will be drawn into this void quite quickly



*Fire spread into bathroom via plastic duct
(Photo courtesy of Greater Manchester Fire & Rescue Service)*

** This liner may, for example, consist of plasterboard tightly fitted at the corners and held in place by silicone sealant or the duct may be wrapped in a suitable intumescent-based liner.

11.5 Any void between two joists that contain such a duct which is running parallel with the joists should be lined on the face of both joists with fire protection board that duplicates the fire protection provided by the ceiling lining. The void beyond the duct should be separated by a transverse barrier of the same rating. Similarly, the flooring above may need to be underdrawn with fire protection board if it is butt-jointed. The method of fire sealing the wall/duct interface will vary depending upon whether it is a studded construction or a conventional masonry cavity wall (see Figures 11a and 11b).

11.6 Where the duct runs transverse to the joists, the amount of joist to be cut away is likely to be structurally significant and expert guidance should be sought, in respect of both the effect on the structure and the fire separation measures.

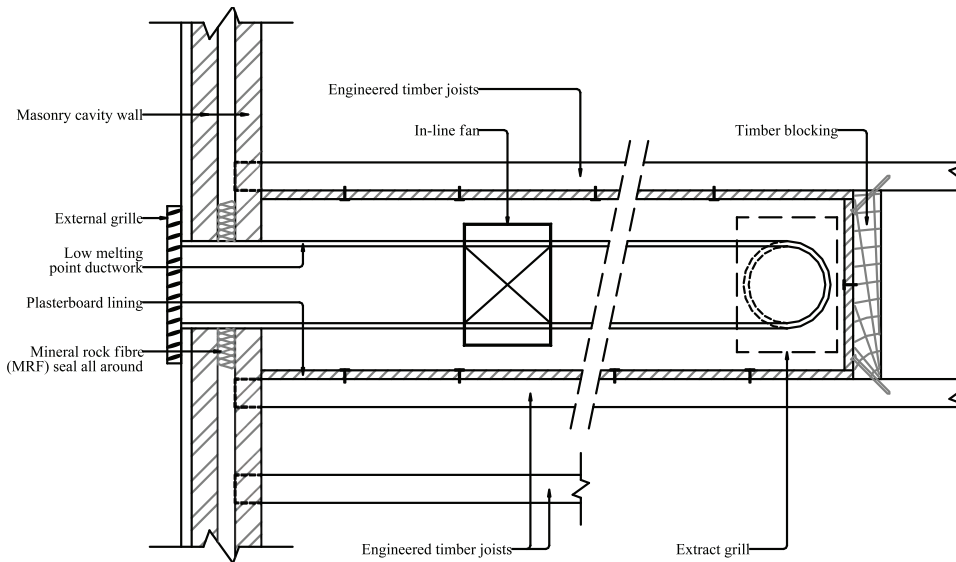


Figure 11a: Joist/wall protection when installing vent into conventional masonry wall construction

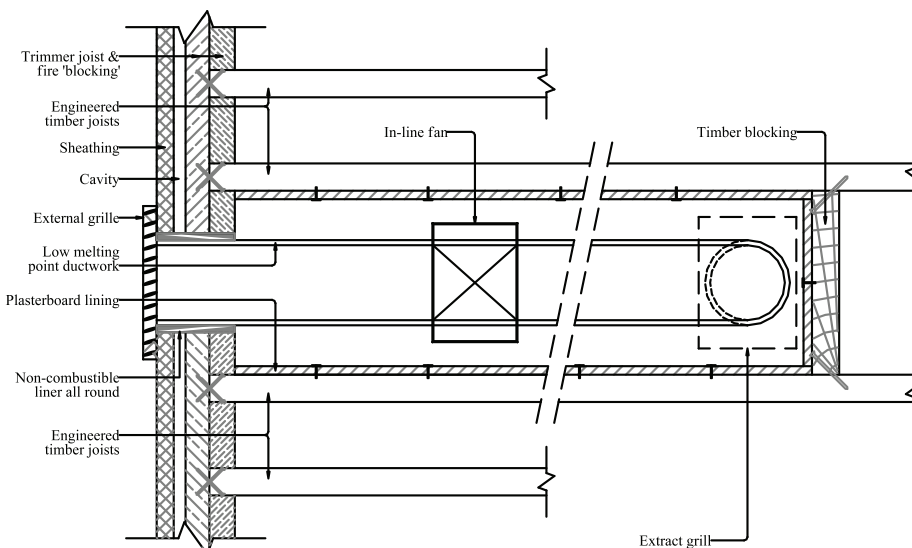


Figure 11b: Joist/wall protection when installing vent into timber frame wall construction

12 Wall or ceiling-mounted electrical equipment

- 12.1 It has become increasingly common to mount heavy equipment such as TVs, speakers, flat screen installations etc on wall brackets, and to hang heavy luminaires, lighting track and projectors etc from the ceiling.
- 12.2 Plasterboard linings are not designed to carry such weights under fire conditions and, unless these items are fixed back **only** to the structural members in the wall or floor, they will pull down the linings once the board is weakened by the fire.
- 12.3 Weakening of normal and 'sound' grade plasterboard will occur rapidly after fire has consumed the room face paper lining and, whilst fibreglass-reinforced board will not fail quite as quickly or as dramatically, fixings will pull through it at a fairly early stage in the fire attack.
- 12.4 Obviously, early failure of these protective linings will allow fire attack on the studs and joists which again, if of engineered construction (see Annex A) will lead to premature structural failure.



Photo courtesy of CEDIA/Smartcomm

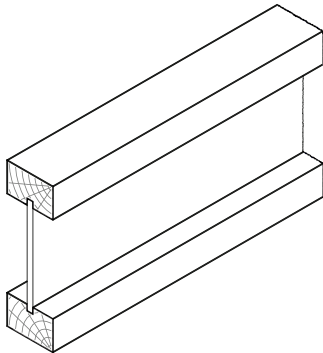
- 12.5 All heavy equipment mounted on the face of walls or hung from the ceiling must be supported **completely** independently from the fire protective plasterboard linings. Whilst it may be permitted to fix directly to the joists, false ceiling members or studs, none of the fixings should rely solely on plasterboard.
- 12.6 If any additional fixings are needed beyond those that the structure is able to provide, then a section of the lining should be completely removed and the edges of the 'hole' fitted with supports to which 'both' edges of the plaster board can be fixed.

- 12.7 Additional structural members should then be fitted between joists and studs at the required fixing locations and the new plasterboard should be scribed, cut to size/shape and fixed in accordance with plasterboard manufacturers' instructions, before fitting the suspended equipment. Joints between existing and new plasterboard linings should be filled and skimmed with plaster.

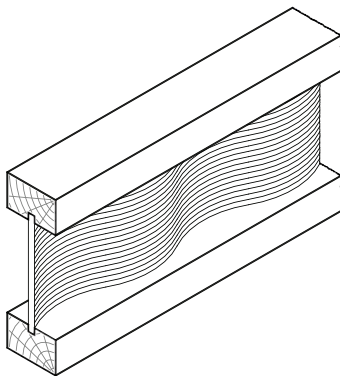
ANNEX A

Examples of forms of modern engineered construction covered by this Guide.

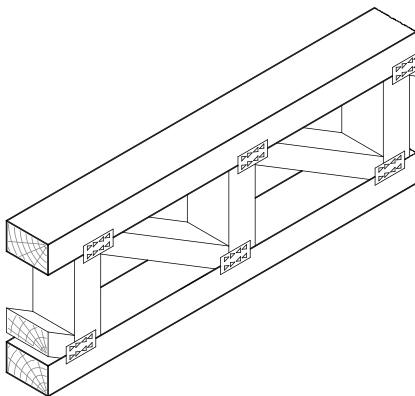
Floor Joists



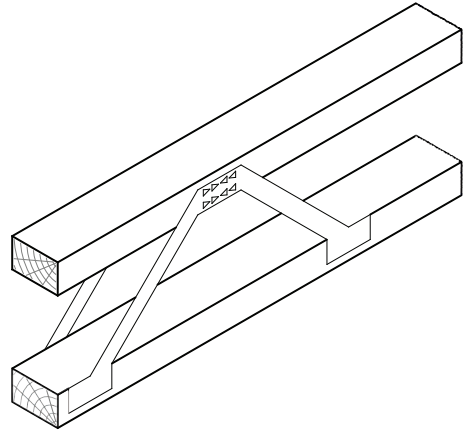
Timber 'I' beams; consisting of Orientated Strand Board (OSB) or plywood webs with solid timber or laminated timber top and bottom chords.



Steel webbed, timber 'I' beams; consisting of corrugated steel webs with timber top and bottom chords



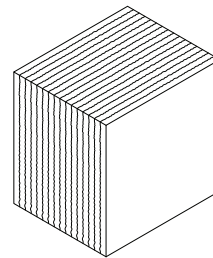
Punched metal plate connected 'truss' joists



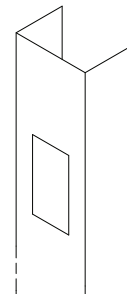
Space joists; consisting of timber top and bottom chords spaced apart by pressed steel 'boomerangs'

Narrow stress graded softwood joists (less than 38mm)

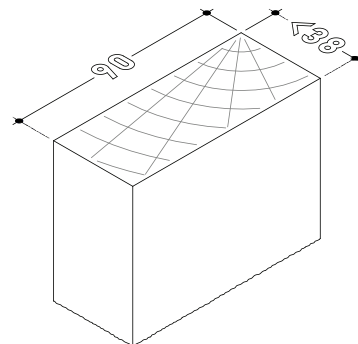
Studs



Glue laminated 'timber' studs



Steel 'C' studs



Narrow stress graded softwood studs (less than 38 mm)

ANNEX B

Under regulatory guidance there are a number of fire tests called up against which the elements, together with installed components as they will be in practice, have to be verified. The ability of the element to satisfy the structural fire requirements and fire separating objectives is adjudged by a series of established British and European test procedures.

The relevant standards are:

- Non-loadbearing walls and ceiling membranes: BS 476: Part 22: 1987, or BS EN 1364: Parts 1 and 2.
- Loadbearing walls and floors; BS 476: Part 21: 1987, or BS EN 1365: Parts 1 and 2.
- Wires, cables and conduit penetrating elements; BS EN 1366-3.
- Suspended ceilings that are provided only for the protection of steel beams*; BS 476: Part 23: 1987. Note there is no directly comparable BS EN test for this purpose.

In respect of these tests, the criteria of failure are loadbearing capacity (BS 476 Part 21 and BS EN 1365 only), integrity and insulation, which are defined as follows:

Loadbearing capacity is the ability to carry the design loads for the specified period without collapse or exceeding pre-determined deflection limits.

Integrity is the ability to resist the passage of flames, or the passage of critically hot gases (measured by means of an oven dry cotton pad).

Insulation is the ability to restrict temperature rise on the unexposed face to a mean temperature rise of 140 °C and a maximum temperature rise of 180 °C.



Floor above in danger of collapse (Photo courtesy of Greater Manchester Fire & Rescue Service)

**The use of a suspended ceiling provided for the purpose of protecting steel beams in lieu of cladding, or spraying them, is a very restricted application and will rarely be found in the domestic sector. Unfortunately, a number of proprietary products available for protecting downlighters will have erroneously been tested to this standard, but these will not be suitable for 'making good' fixed ceilings or suspended ceilings used to provide protection to 'timber' joisted floors or other 'domestic' forms of construction.*

ANNEX C

Guidance on what constitutes robust construction which identifies where unprotected downlighters may be fitted

When the installer wishes to fit unprotected** downlighters, it is necessary to establish the construction in detail and ensure that the floor is of one of the following constructions;

a) First floor of two-storey house:

- the joists are solid timber not less than 43 mm thick and at no more than 450 mm centres, and
- the floorboards above are either tongue and grooved softwood greater than 18 mm thick or are tight fitting butt jointed softwood boards free from dead knots, or is 'timber' based jointed flooring not less than 18 mm thick, and
- the ceiling consists of 12.5 mm plasterboard or 'sound' lath and plaster with the 'hooks' in good condition.

If downlighters are installed in a compartment floor (or separating floor in Scotland – see Annex F), they must be protected** regardless of the construction.

b) All other floors in a single family unit:

- As for the first floor above, except butt jointed floor boards are not permitted without an overlay of medium density fibreboard (MDF), hardboard or plywood not less than 4 mm thick.

c) One hour fire resisting floors between flats:

- the joists are solid timber not less than 43 mm thick and at no more than 450 mm centres, and
- the floorboards above are either tongue and grooved softwood boards greater than 18 mm thick and free from dead knots, or is 'timber' based jointed flooring of a similar minimum thickness
- the ceiling consists of two layers of plasterboard, not less than 30 mm¹ thick for non-fire rated board or not less than 25 mm thick of fire rated ¹ & ² board.

***Protected means downlighters that incorporate integral fire protection or which are fitted with fire hoods that comply with the guidance given in Annex E of this Guide.*

¹ Excluding any textured surface which should be removed locally prior to fitting the luminaire

² Type 5 to BS 1230 or Type F to BS EN 520

ANNEX D

Summary of the recommendations given in national regulatory fire safety guidance:

The requirements given in Table 1 and 2 of this Guide are the 'recommendations' made in the Guidance Document published in support of the relevant regional regulations. These Guidance Documents offer a prescriptive solution to the 'functionally' expressed regulations in the relevant region of the UK. At the time of publication, the relevant regional regulations that deal with the fire safety issues are:

England & Wales

The Building Regulations 2000

- Approved Document B
 - Fire Safety (Volume 1)
 - Dwellinghouses (2006 Edition)

Scotland

The Building (Scotland) Regulations 2004

- The Scottish Building Standards Technical Handbook Domestic (2007)

Northern Ireland

The Building Regulations (Northern Ireland) 2000, as amended

- Technical Booklet E, 2005

The above regulations apply only to new build, or to major refurbishments (material alterations) that are notified after the dates given. Buildings already constructed and/or occupied will have complied with the regulations and associated guidance in force at the time of application.

These Guidance Documents would have expressed the recommended fire performance of the structure in terms of the test standards described in Annex B

ANNEX E

Test procedure to evaluate the robustness of downlighter fire hoods

1. INTRODUCTION

This Annex provides requirements¹ that need to be satisfied by a downlighter fire hood that is considered to be 'robust' in both its construction and fitting, and thereby meets the recommendations given in this Guide.

During installation, in order not to compromise the performance of the downlighter, it is essential that the area immediately above the downlighter and the fire hood remains free from thermal insulation (see 7.9). Subsequent to its installation, however, the fire hood needs to demonstrate its ability to remain in place and resist crushing, that is to be 'robust' in the event of any application of thermal insulation or other material by others.

2. SCOPE

The purpose of this test procedure is to assess the ability of a downlighter fire hood which has satisfied the fire test requirements of BS 476: Part 21: 1987 to retain its mechanical stability over its working life whilst providing the requisite level of fire protection to the structure of the building from a downlighter located beneath.

3. TEST PROTOCOL

The test protocol is a two part test. The first part deals with the ability of the specimen fire hood to resist compression after the application of the insulation within the test frame. The second part deals with the ability of the fire hood to resist dislodgement subsequent to installation.

4. TEST EQUIPMENT

The test assembly is designed to simulate a domestic ceiling. It consists of two softwood floor joists 225 mm x 47 mm x 1500 mm long held 450 mm apart, being screwed to similar sectioned timbers at either end.

The base of the test construction consists of a single sheet of 12.5 mm type plasterboard nailed to the underside of the timber framework. Two further sheets of 12.5 mm plasterboard 1500 mm x 300 mm are screwed to the inner face of the two major timber sections in a vertical position.

Midway down the length of the frame, a hole is cut in the centre of the plasterboard on the underside of the test frame. The size of the hole so cut should be equal to that formed in the ceiling to accommodate the downlighter that the fire hood is designed to protect.

A 1400 mm length of 400 mm wide mineral wool (24 kg/m³) is cut sufficient to provide an overall insulation depth of 270 mm within the test frame. The test assembly is held in position 2 m above ground level by the use of appropriate scaffolding.

5. TEST PROCEDURE

5.1 Compression test

The specimen fire hood is located above the hole in the manner prescribed by the manufacturer. Unless the device is identified as being suitable only for installation from above, this will be positioned from below.

Once the specimen has been located in position, the distance between the top innermost part of the fire hood and the lower surface of the plasterboard of the main structure shall be measured in at least 3 places, averaged and noted (a).

¹These test requirements have been developed by IFSA, the Intumescent Fire Seals Association. IFSA is a recognized trade association for manufacturers of intumescent materials and intumescent-based systems, membership of which requires all product claims to be substantiated.

Once this has been ascertained, the insulation described above is laid down the length of the test rig so as to be resting on the upper surface of the plasterboard and specimen.

At this point, the distance referred to above will be measured again (b). The insulation shall remain in place for 25 days. After this period, the distance referred to above will be measured once more (c).

Once the above distances have been ascertained, the insulation should be removed and the 'dislodgement test' should be undertaken on the same test specimen

5.2. Dislodgement test

One end of the test assembly will remain supported via a 'hinge', whilst the opposing end is progressively raised or lowered at a rate of 100 mm/sec until either:-

- a) the specimen fire hood becomes dislodged, in excess of the permitted amount or
- b) the test assembly reaches an angle of 45 degrees.

6. PERFORMANCE CRITERIA

6.1. Compression test

In the case of the second measurement (b), a reduction in the average distance of less than 5%, or 5 mm (whichever is the smaller) is acceptable. For any reduction in excess of this figure, the specimen is deemed to have failed. In the case of the third measurement (c), there should be no further reduction in distance measured.

6.2. Dislodgement test.

If the specimen moves laterally by more than 10 mm or a gap of 3 mm appears between the specimen and the top surface of the plasterboard prior to, or on completion of, the movement test, then the specimen will be deemed to have failed.

ANNEX F

Glossary of terms

Luminaire – equipment which distributes, filters or transforms the light transmitted by one or more lamps, and which includes all the parts necessary for supporting, fixing and protecting the lamps, but not the lamps themselves and, where necessary, circuit auxiliaries together with the means for connecting them to the supply.

Critical application – An application where the consequences of a failure to provide the fire resistance requirements for an element will have a direct impact on the life safety of the occupants, e.g. between adjacent dwellings.

Compartment wall/floor – known in Scotland as separating wall/floor.

‘Modified’ fire resistance – In domestic applications the fire resistance of the first floor has a loadbearing capacity of 30 minutes, but the integrity and insulation criteria are reduced (modified) to only 15 minutes.

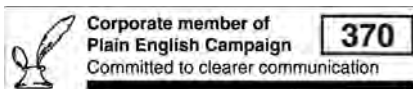
House in Multiple Occupation - For England and Wales, the legal definition of a House in Multiple Occupation is to be found in Sections 254-260 and Schedule 14 of the Housing Act 2004 or, in the case of Scotland, the Civic Government (Scotland) Act 1982 (Licensing of Houses in Multiple Occupation) Order 2000 as amended.

‘Separating floor and wall’ means in Scotland a floor or wall constructed to prevent the spread of fire between buildings or parts of buildings of separate habitation, such as flats and maisonettes.

Three-storey house: A house in single occupation with two floors above ground floor levels, often referred to as a town house.

House of four storeys, or more: A house that has three or more floors above ground floor where the height of the uppermost floor does not exceed 18 m.

The latest versions of all the **BestPractice** Guides are available to download from www.electricalsafetyfirst.org.uk



Electrical Safety First

Unit 331, Metal Box Factory, 30 Great Guildford Street, London SE1 0HS

Helpline: 020 3463 5100

Email: enquiries@electricalsafetyfirst.org.uk Web: www.electricalsafetyfirst.org.uk

Registered Charity (England and Wales) No.257376 (Scotland) No. SC039990

Electrical Safety First is the UK charity dedicated to reducing deaths and injuries caused by electrical accidents. Our aim is to ensure everyone in the UK can use electricity safely

**Electrical
Safety First** 
The UK's electrical safety experts